

ProfiMaster

EN – Operating Manual

Typenschild einkleben

1	General	- 7 -
1.1	Introduction.....	- 7 -
1.2	References to copyright and industrial property rights.....	- 7 -
1.3	Notes for the operating company	- 7 -
2	Safety.....	- 9 -
2.1	General information	- 9 -
2.2	Information on signs and symbols.....	- 9 -
2.3	Markings/signs to be affixed by the operating company	- 10 -
2.4	Safety instructions for operating staff	- 10 -
2.5	Safety instructions for maintenance/troubleshooting.....	- 11 -
2.6	Notes regarding special types of hazard	- 11 -
3	Product information.....	- 15 -
3.1	Functional Description	- 15 -
3.2	Distinguishing feature – W3 certified	- 15 -
3.3	Distinguishing feature – 1 or 2 extraction arms.....	- 16 -
3.4	Intended use	- 17 -
3.5	Ambient conditions	- 18 -
3.6	General requirements in accordance with DIN EN ISO 21904	- 20 -
3.7	Reasonably foreseeable misuse.....	- 20 -
3.8	Markings and signs on the product.....	- 21 -
3.9	Residual Risk	- 21 -
4	Transport and Storage	- 23 -
4.1	Transport	- 23 -
4.2	Storage	- 23 -
5	Assembly.....	- 24 -
6	Use	- 26 -
6.1	Qualification of the operating personnel	- 26 -
6.2	Operating controls	- 26 -
6.3	Positioning the extraction hood	- 28 -
6.4	Commissioning	- 29 -
7	Maintenance	- 31 -
7.1	Care.....	- 31 -
7.2	Maintenance.....	- 32 -

7.2.1	Special Notes on Laser Welding	- 32 -
7.2.2	Changing the filter – Safety instructions.....	- 32 -
7.2.3	Changing filters.....	- 34 -
7.3	Troubleshooting.....	- 37 -
7.4	Emergency measures	- 37 -
8	Disposal	- 39 -
8.1	Plastics	- 39 -
8.2	Metals.....	- 39 -
8.3	Filter elements.....	- 39 -
9	Annex	- 40 -
9.1	EU Declaration of Conformity.....	- 40 -
9.2	UKCA Declaration of Conformity	- 41 -
9.3	Technical data.....	- 42 -
9.4	Dimensions sheet.....	- 43 -
9.5	Spare parts	- 44 -
9.6	Accessories	- 44 -

1 General

1.1 Introduction

This manual is an essential aid for the proper and safe operation of the product.

These operating instructions contain important information to ensure safe, proper and efficient operation of the product. Observing these instructions helps avoiding danger, reducing repair costs and downtimes and increasing the reliability and service life of the product. The operating instructions must be kept available at all times and have to be read and applied by every person who is assigned to work on or with the product.

These include amongst others:

- the operation and troubleshooting during operation
- the maintenance (care, maintenance, repair)
- the transport
- the assembly
- the disposal

Technical modifications and errors expected.

1.2 References to copyright and industrial property rights

These operating instructions are to be kept confidential and made accessible only to authorised persons. Disclosure to third parties is only permitted with the prior written consent of the manufacturer KEMPER GmbH.

All documents are protected under the Copyright Act. Any form of disclosure, reproduction, or partial use, as well as the communication of its content, is prohibited without express written permission.

Violations will be prosecuted under criminal law and will incur liability for any resulting damages.

Industrial property rights such as patents, trademarks, or designs are exclusively held by the manufacturer.

1.3 Notes for the operating company

The operating instructions are an essential part of the product.

The operating company must ensure that the operating personnel is aware of the contents of this manual.

Based on national regulations for accident prevention and environmental protection, the operating instructions are to be supplemented by the operating company's own operating instructions, including information on regulatory and reporting requirements to meet specific operating requirements, such as work organisation, work flow and staff employed. In

addition to the operating instructions and the relevant obligatory regulations for accident prevention applicable in the country of use, it is also imperative to comply with the recognised technical rules for safe and professional handling.

Without prior consent from the manufacturer, the operating company may not carry out any changes, conversions or additions to the product which may impair safety. Spare parts used must comply with the manufacturer's specified technical requirements. This is always the case with original replacement parts.

Only use trained and instructed staff for the operation, maintenance, repair and transport of the product. Clearly define for staff who is responsible for operation, maintenance and transport.

2 Safety

2.1 General information

The product is designed and built according to state-of-the-art technology and the recognised safety rules and regulations. When operating the product, technical hazards for the operator or impairment of the product as well as other property may occur, if:

- it is not operated by trained or instructed personnel
- it is not used for the purpose intended and/or
- it is improperly maintained

2.2 Information on signs and symbols

▲ DANGER

This symbol in conjunction with the signal word "Danger" indicates imminent danger. Non-adherence of the safety note leads to death or serious injuries.

▲ WARNING

The symbol in conjunction with the signal word "Warning" indicates a potentially dangerous situation. Non-adherence to the safety notice may lead to death or serious injuries.

▲ CAUTION

The symbol in conjunction with the signal word "Caution" indicates a potentially dangerous situation. Non-adherence of the safety note may lead to slight or negligible injuries.

May also be used for warnings against property damage.

NOTE

The general information is simple additional information which does not warn about personal injury or property damage.

1. Enumerations of action steps are marked as numbers with a dot, where the order is important.
- Bullet points indicate lists of parts in a legend or instructions for which the sequence is unimportant

2.3 Markings/signs to be affixed by the operating company

The operating company is obliged to post further markings and signs on the product and the surrounding area if necessary.

Such markings and signs might be related, for example, to the requirement for wearing personal protective equipment.

2.4 Safety instructions for operating staff

Before use, the operator of the product must be instructed through information, instructions and training on the handling of the product and the materials and aids to be used.

The product system may only be used in technically perfect condition, for its intended purpose, in full awareness of the safety aspects and potential dangers and in accordance with these instructions. All errors, especially those that may affect safety, must be removed immediately.

Every person who is charged with commissioning, operation or maintenance must have fully read and understood these operating instructions. This specifically applies to staff who only operate the product occasionally.

The operating instructions must always be within reach of the product.

We accept no liability for any damages or injuries caused by failure to observe these operating instructions.

The relevant accident prevention regulations and other generally recognised safety and occupational health regulations must be observed.

The responsibilities for the various activities included in maintenance and repair must be clearly defined and adhered to. Only then will human error - especially in dangerous situations - be avoided.

The operating company is to enforce wearing of personal protective equipment by operating and maintenance staff. These include in particular safety shoes, safety glasses and gloves.

Do not wear loose, long hair, loose clothing or jewellery. In theory, there is a risk of getting caught on something, or being pulled in or dragged along by moving parts.

If there are any safety-related changes to the product, immediately halt the process, secure it and report the occurrence to the relevant authority/person!

Work on the product may only be carried out by reliable, trained staff. Observe the minimum legal age.

Staff who require training, teaching or instructing or staff who undergo a general apprenticeship may only operate the product under the supervision of an experienced member of staff.

2.5 Safety instructions for maintenance/troubleshooting

Service and maintenance doors must be freely accessible at all times.

Setting up, maintenance and repair work and troubleshooting must only be performed when the product is switched off.

Always tighten bolt connections that have been loosened during repair work. If specified, tighten the relevant bolts with a torque wrench.

In particular, protect connections and screw connections from dirt or care products at the beginning of maintenance/repair/care

The time frames for periodic testing/inspections stipulated or specified in the operating instructions must be observed.

Before disassembling, mark the parts that belong together.

2.6 Notes regarding special types of hazard

⚠ DANGER

Danger of electric shock!

Any work on the electrical equipment of the product must only be performed by a qualified electrician or by operating personnel under the direction and supervision of a qualified electrician in accordance with electronic regulations.

Before opening the product, pull the plug, if available, and secure it against accidental switch-on.

For faults with the product's electrical energy supply, immediately switch the product off at the on/off switch and if available, also pull the plug.

Use only original fuses with the prescribed amperage.

Electrical components, on which inspection, maintenance and repair work must be carried out, must be disconnected from the power supply. Secure equipment that has been used for disconnection against unintentional or automatic reconnection. Firstly check that no voltage is present in activated, electrical components, then isolate adjacent components under voltage. When making repairs, ensure that constructive characteristics are not altered in a way that reduces safety.

Check cables regularly for damage and replace if necessary.



CAUTION: Automatically Operated Device – To Reduce The Risk Of Injury Disconnect From Power Supply Before Servicing.

WARNING: To Reduce The Risk Of Electric Shock, Do Not Expose to Water or Rain.

ATTENTION: Appareil fonctionnant automatiquement – afin de réduire les risques de blessure, débrancher l'alimentation électrique de procéder à l'entretien.

AVERTISSEMENT: Pour réduire le risque de choc électrique, ne pas exposer à l'eau ou à la pluie.

⚠ WARNING**Electric shock if earthing is missing!**

If the protective earth connection of devices is missing or incorrectly executed, high voltages may be present on exposed parts or housing parts which, if touched, can lead to serious injury or death.

⚠ WARNING**Electric shock if an unsuitable power supply is connected!**

The connection of an unsuitable power supply can cause parts that can be touched to be under dangerous voltage. Contact with dangerous voltage can lead to serious or fatal injury.

For electrical connection data, see the name plate of the product

Power supply

The product is designed for the mains voltage indicated on the name plate. If mains cables or mains plugs are not fitted to the product, they must be fitted in accordance with national standards.

⚠ CAUTION**Insufficiently dimensioned electrical installation can lead to serious damage to property.**

The mains supply line and its fuse protection must be designed in accordance with the existing power supply. Observe the technical data on the name plate.

The mains fuse should be equipped with at least a **category C** circuit breaker.

⚠ WARNING

Danger from toppling over during transport!

The product may tilt and topple over when moved. People can be injured due to the high dead weight.

- Before moving, release the brakes on the castors.
- Move and set down the product only on flat, smooth floor coverings.
- Only move the product with the push handle.
- Do not use the push handle to lift the product.
- Do not sit or climb on the product.
- Before moving; if present, fold in suction arm / wind up or dismantle suction hoses

⚠ DANGER**Danger due to the product tipping!**

For products with two extraction arms, there is the danger that the product may tip over if used improperly.

When positioning the two extraction arms, make sure that the two extraction arms are not swivelled to the same side.

The stability is also influenced by the length and extension of the extraction arms.

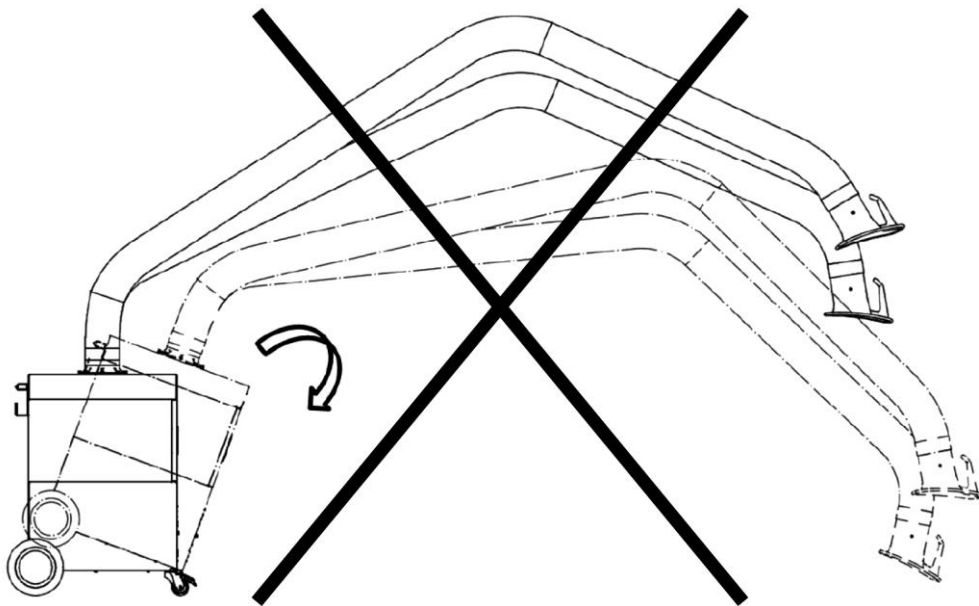

Fig. 1: Improper positioning of the extraction arms

⚠ WARNING**Health hazards caused by welding fume particles**

Do not inhale welding dust / smoke! Serious injury to the lungs and respiratory tract is possible!

Sweat smoke contains substances that can cause cancer!

Skin contact with cutting and welding fumes etc. can cause skin irritation in sensitive persons!

Repair and maintenance work on the product may only be carried out by trained and authorised personnel while complying with the safety rules and the applicable accident prevention regulations.

To avoid contact with and inhalation of the dust particles, wear disposable overalls, protective goggles, gloves and a suitable Class FFP2 respiratory protection filter mask in accordance with EN 149.

The release of hazardous dust particles during repair and maintenance is to be avoided to ensure that persons not charged with the task are not affected.

⚠ CAUTION**Health hazard due to noise!**

The product can produce noise, please refer to information in the technical data. In connection with other machines and/or local conditions, a higher noise level can occur at the operation site of the product. In this case, the operating company is obliged to provide the operating personnel with the appropriate protective equipment.

3 Product information

3.1 Functional Description

The product is a compact welding fumes filter device that extracts welding fumes at the point where they are produced and extracts them with a filter efficiency of more than 99%.

The extracted contaminated air is cleaned using a 2-stage filter method and then fed back into the workspace.

The product is equipped with a flexible extraction arm whose extraction hood is easy to move and is self-supporting in any position.

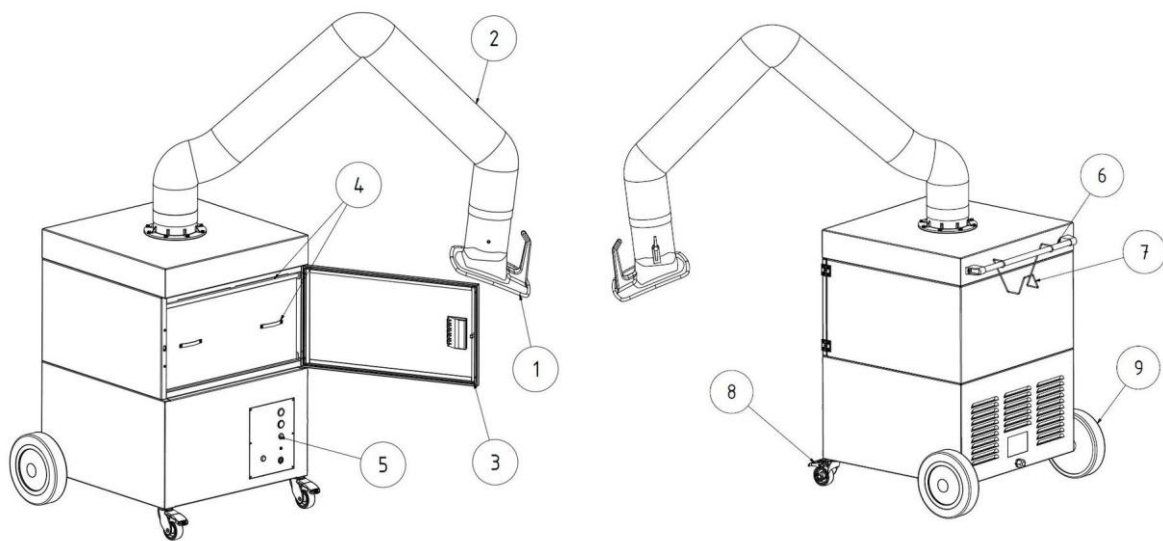

Fig. 2: Product description

Pos.	Designation	Pos.	Designation
1	Extraction hood	6	Handle bar
2	Extraction arm	7	Cable holder
3	Maintenance door	8	Swivel castor with brake
4	Filter insert	9	Rear wheel
5	Operating controls/Control unit box		

Tab. 1: Positions on the product

3.2 Distinguishing feature – W3 certified

The product is manufactured in two versions:

- **Version – non W3 certified**

- **Version – W3 certified**

Attention

Only products labelled with the W3 sticker have been tested and certified accordingly.

See also chapter technical data: Welding fume class and test standard.

W3-tested:

The product has been tested by the IFA (Institute for Occupational Safety and Health of the German Social Accident Insurance Institutions). It fulfils the requirements of welding fume separation class W3 and conforms to EN ISO 21904-1.

The tested products are labelled with the DGUV test mark and a W3-tested (marking of the welding fume separation class) in the form of a sticker.

Labelling on the product	Meaning/explanation	Reference logo
W3 sticker	Type "W3 certified" according to test standard – see chapter "Technical data"	

Tab. 2: W3 label

3.3 Distinguishing feature – 1 or 2 extraction arms

The product is manufactured in two versions:

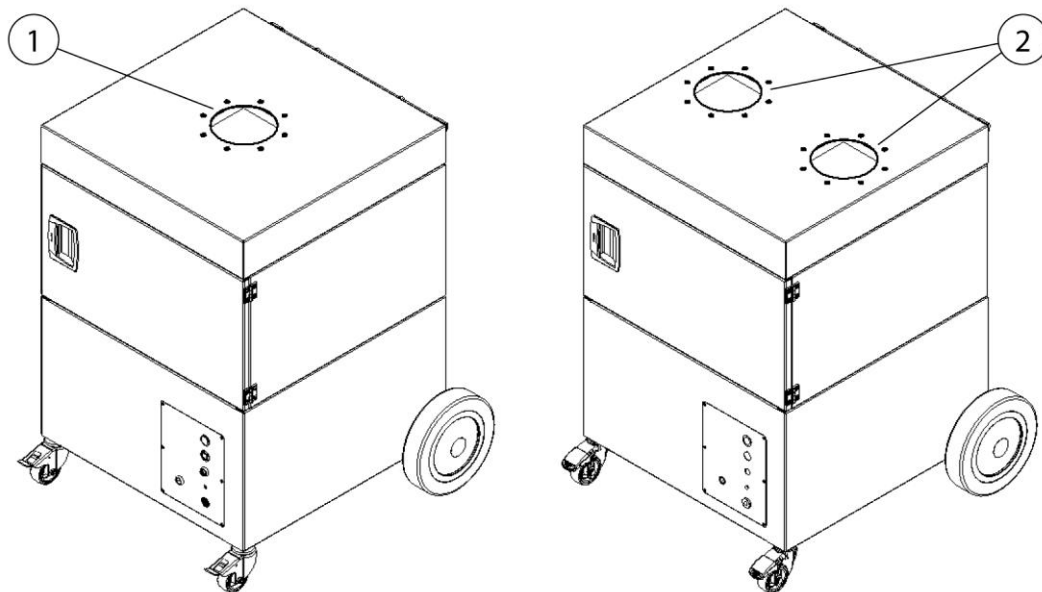

Fig. 3:

Pos.	Designation	Pos.	Designation
1	Product for 1 extraction arm	2	Product for 2 extraction arms

Tab. 3: Distinguishing features – 1/2 extraction arms

- Version – product with 1 extraction arm – W3/IFA certified.
- Version – product with 2 extraction arms (optional) – **not** W3/IFA certified.

3.4 Intended use

This product is designed to extract and filter welding fumes produced during the welding of metallic materials at the point of origin.

This product must only be used for processes in which no incandescent sparks or flammable particles are drawn in.

Dimensions and further product details that must be observed can be found in the technical data.

NOTE



Only products labelled with the W3 sticker have been tested and certified accordingly. See also chapter Technical data: Welding fume class and test standard.

NOTE

When welding alloyed or high-alloy steels with filler metals above 5% chromium/nickel, carcinogenic CMR substances (carcinogenic, mutagenic, reprotoxic) are released. In accordance with official regulations, only tested and approved products may be operated in Germany to extract these harmful smoke particles using the so-called recirculation method.

Only products that meet the requirements of welding fume separation class W3/IFA certified may be operated for the aforementioned welding processes using the recirculation method.

When extracting welding fumes with carcinogenic components (e.g. chromates, nickel oxides, etc.), the requirements of TRGS 560 (technical rules for HAZMAT) and TRGS 528 (welding work) must be obeyed.

NOTE

The information in the "Technical data" chapter must be observed and strictly adhered to.

Intended use also includes observation of the instructions and information on

- safety
- operation and control
- maintenance and servicing

contained in this manual.

Any other use or use going beyond this is considered improper use. The company operating the product is solely responsible for any damage resulting from it. This also applies to unauthorised modifications to the product.

3.5 Ambient conditions

Operation or storage of the device outside the specified area is deemed unintended use and may impair the function, the extraction capacity and

the protective effect in accordance with DIN EN ISO 21904. The manufacturer is not liable for any resulting damage.

General:

- Ambient air free from dust, acids, corrosive gases or other aggressive substances.
- Height above sea level: up to 1000 m [3281 ft].
- For accordingly released products only: Indoor or outdoor operation permitted.

Temperature range of the ambient air:

Operating mode	Operation	Transport/ storage
Indoor (Indoor area)	+5 °C to 40 °C [+41 °F to +104 °F]	-20 °C to +50 °C [-4 °F to +122 °F]
Outdoor (For approved products only)	-10 °C to 40 °C [+14 °F to +104 °F]	-20 °C to +50 °C [-4 °F to +122 °F]

Table 4: Temperature range of the ambient air

Relative humidity (non-condensing unless approved otherwise):

- **Indoor:** up to 50% at +40 °C [+104 °F], up to 90% at +20 °C [+68 °F]
- **Outdoor:** up to 100%, including temporary condensation due to weather conditions

3.6 General requirements in accordance with DIN EN ISO 21904

NOTE

Connection of ducting systems, extraction arms and hoses.

Ducting systems, extraction arms and hoses connected to the product can lead to a pressure drop and must be taken into account by the system designer or user.

The connected components must be suitable for the product and ensure the required minimum volume flow (extraction capacity).

A possible design of the ducting can be requested from the manufacturer.

The connected components must be checked regularly for proper seating, leaks and blockages.

The required extraction capacity must be checked at the central extraction element.

NOTE

Returning the air to the workplace atmosphere

In some Federal States, recirculation of air into the workplace atmosphere is not recommended or is prohibited. It may be necessary to conduct the exhaust air to the outside via a duct.

3.7 Reasonably foreseeable misuse

No reasonable, foreseeable misuse is possible that could lead to dangerous situations with personal injury when working with the product whilst adhering to its intended use.

The operation of the product in industrial areas that do not comply with the requirements for explosion protection is not permissible.

Furthermore, the operation is prohibited for:

1. Processes that are not in the intended use list and in which the extracted air is:
 - is mixed with sparks, e.g. from grinding processes, which due to their size and quantity might lead to damage to the filter media or even to a fire;

- mixed with liquids and the resulting contamination of the air flow with vapours containing aerosols and oils;
 - mixed with highly flammable, combustible dust and/or with substances that can form explosive mixtures or atmospheres;
 - is mixed with other aggressive or abrasive dust that could damage the product and the filter elements employed;
 - is mixed with organic, toxic substances or a proportion of substances that are released when cutting the material.
2. Outdoor locations where the product is exposed to weather conditions because the product must only be installed in closed buildings. If there is an outdoor variant of the product available, this may be installed outside. Please note that additional accessories may be required for the outdoor installation.

3.8 Markings and signs on the product

Various markings and signs are affixed to the product. If these are damaged or removed, please replace them immediately with new ones in the same location.

The operating company is obliged to post further markings and signs on the product and the surrounding area if necessary.

Such notes and signs might be related, for example, to the requirement for wearing personal protective equipment.

In the country of use, additional required safety instructions and pictograms can be provided by the manufacturer in accordance with applicable law.

3.9 Residual Risk

Even when all safety rules are observed, when operating the product a residual risk remains, as described below.

All persons working on and with the product must be aware of these residual risks and follow the instructions that prevent these residual risks from causing accidents or damages.

⚠ WARNING

Danger of serious injury to the lungs and respiratory tract – always wear respiratory protection, Class FFP2 or higher.

Skin contact with welding fume particles may cause skin irritation in sensitive persons – wear protective clothing.

Before starting the welding process, ensure that the product is properly adjusted and in operation. The filter elements must be complete and in undamaged condition.

The connected detection element must reliably detect the welding fumes. For the correct positioning, refer to the documentation of the detection element.

When changing the filter inserts, skin contact with the separated dust particles may occur and parts of the dust particles may also be stirred up by the work. Respiratory protection and protective clothing must be worn.

Embers in the filter elements may cause smouldering fires – switch off the product, close the damper flap in the collection element if fitted and let the device cool down in a controlled manner.

⚠ WARNING

When extracting welding fume particles from laser welding processes, the collected dust may become more reactive, depending on the material, process parameters and operating conditions.

Under unfavourable conditions, this can lead to the heating of dust deposits and, in isolated cases, to smouldering processes in the filter or dust collection container.

This behaviour is highly dependent on the specific application (e.g. material, coatings, contaminants such as oil or grease) and does not occur in all applications.

To minimise potential risks, the following measures in particular must be observed:

- Regular inspection and emptying of the dust collection container
- Adherence to or adjustment of maintenance intervals
- Do not mix different types of dust
- Take process conditions and material influences into account

4 Transport and Storage

4.1 Transport

⚠ DANGER

Life-threatening crushing possible when loading and transporting the product!

Improper lifting and transporting may cause the pallet (if present) to tilt and fall!

- Never stand under suspended loads.
- Observe the permissible loads of the transport and lifting aids.
- Observe the applicable accident prevention and occupational safety regulations.

For transporting products with a pallet, use a suitable pallet truck or forklift. The weight of the product can be found on the name plate.

4.2 Storage

The product must be stored in its original packaging at an ambient temperature of 20 °C to +50 °C in a dry and clean place. The packaging must not be loaded by other objects.

The storage duration is not critical for all products.

5 Assembly

NOTE

The product operator may only assign the independent assembly of the product to personnel who are familiar with this task.

Two people are needed to assemble the product.

You must ensure that the welding current return line between the workpiece and the welding machine has a low resistance and that connections between the workpiece and the product are avoided so that the welding current cannot flow back to the welding machine via the product's protective conductor.

NOTE

If add-on products are also present, follow the appropriate manuals when assembling them.

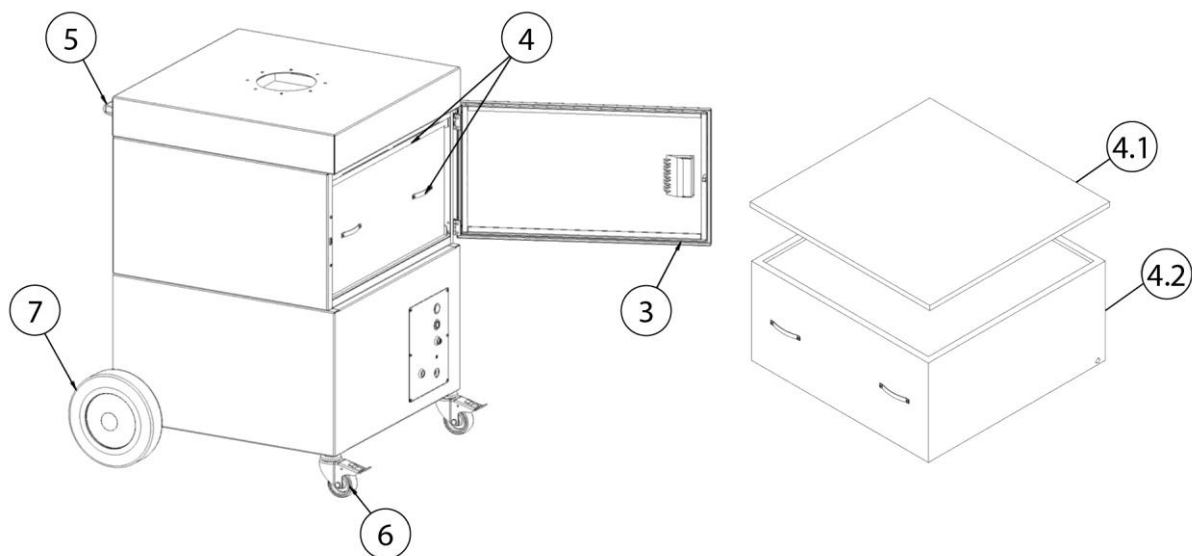

Fig. 4: Assembly

Pos.	Designation	Pos.	Designation
3	Maintenance door	5	Handle bar
4	Filter insert	6	Swivel castor with brake (front wheel)
4.1	Pre-filter insert	7	Rear wheel
4.2	Main filter		

Tab. 5: Positions on the product

6 Use

Every person who deals with use, maintenance and repair of the product must have thoroughly read these operating instructions as well as the instructions for any attachment and accessory products and have understood them.

6.1 Qualification of the operating personnel

The operating company of the product may only commission persons to use the product independently if they are well-versed in this task.

Those familiar with this task includes those who have been instructed appropriately in the task and know the operating instructions as well as the operational issues in question.

The product should only be used by trained or instructed personnel. This is the only way to ensure safety and hazard awareness of all personnel during work.

6.2 Operating controls

Operating controls and connection options are located on the front side of the product:

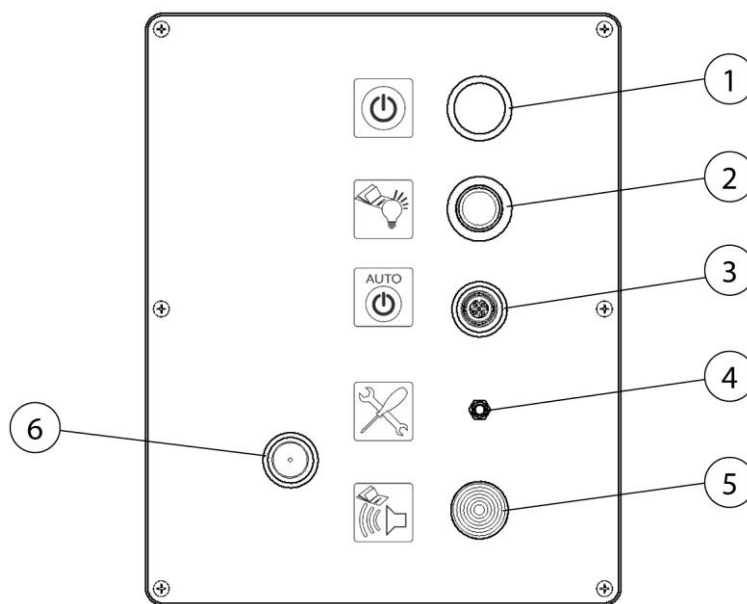



Fig. 5: Operating controls

Pos.	Designation	Note
1	On/Off switch	
2	Signal light	
3	Installation opening for start/stop connection socket (optional fitting) (closed with dummy plug)	
4	Pressure measurement opening (only for service employees)	
5	Signal horn	
6	Pressure switch (closed with dummy plug) (service personnel only)	

Tab. 6: Operating controls

- **I/O switch (Pos. 1)**

The product is switched on and off by pressing the switch.

The green indicator lamp of the switch indicates trouble-free operation of the product or the readiness for operation when using an optional start/stop sensor.

- **Indicator lamp (Pos. 2)**

If the yellow indicator lamp lights, the following faults may have occurred:

- *Motor protection switch has triggered*
- *Phase error/missing phase*
- *Filter change necessary*

- **Installation opening for start/stop connection socket (Pos. 3)**

Installation opening for the optional fitting of the automatic start/stop system.

- **Pressure measuring opening (Pos. 4)**

Connection facility for our service department. Our service department can take pressure measurements using this connection.

NOTE



- **Signal horn (Pos. 5)**

Reliable capture of welding fumes is only possible with sufficient extraction capacity. As the dust accumulation in the filter increases, its flow resistance increases and the extraction capacity decreases.

As soon as it drops below a minimum value, the signal horn sounds.

A filter change is now required.

The same happens if the damper flap in the extraction hood is closed too far and the extraction capacity is reduced too much.

This situation can be remedied by opening the damper flap.

- **Pressure switch (Pos. 6)**

Our service department can carry out adjustments to the product using this interface. Only to be used by the manufacturer's service department.

6.3 Positioning the extraction hood

The extraction arm or extraction hood is designed in such a way that it can be adjusted and moved easily by hand. Once it has been positioned, the extraction hood maintains its set position of its own accord. Furthermore, both the extraction hood and the arm can be pivoted through 360° so that almost any position can be set. It is important that the extraction hood is always positioned properly in order to achieve adequate capture of the welding fumes. The correct position is shown on the following image.

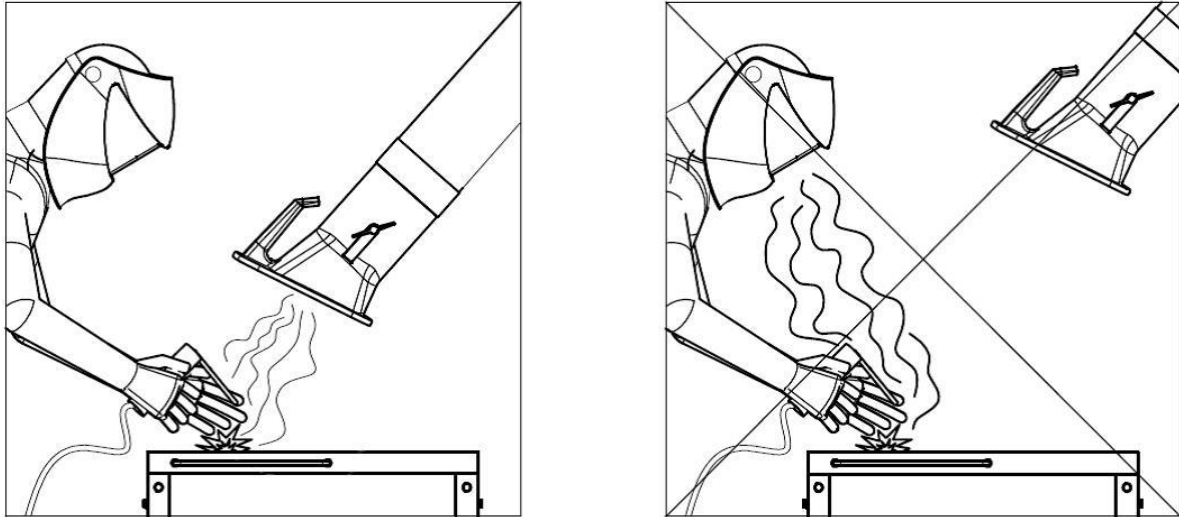

Fig. 6: Positioning the extraction hood

- Position the extraction arm so that the extraction hood is located approx. 25 cm diagonally above the weld.
- The extraction hood must be positioned so that it safely captures the welding fumes, taking into account the movement of welding fumes caused by the heat and the extraction range.
- Always move the extraction hood with respect to the weld position as you advance.

▲ WARNING

An incorrectly positioned extraction hood or too low an extraction capacity do not ensure that air containing hazardous substances is captured adequately by the extraction hood. This means hazardous substances can enter the area where the operating personnel breathes and cause severe damage to health.

6.4 Commissioning

▲ WARNING

Danger due to faulty product condition.

The product must be fully installed before commissioning begins. All doors must be closed and the necessary connections must have been made.

1. Connect the power supply connection cable of the product to the on-site power supply.
2. Switch the product on using the pushbutton marked "0" and "I".
3. The fan starts and the green indicator lamp on the device switch indicates error-free operation.

If there is a fault, please refer to the "Troubleshooting" chapter.

7 Maintenance

The instructions in this chapter are intended as minimum requirements. Depending on the operating conditions, further instructions may be required to keep the product in optimal condition.

The maintenance and repair work described in this chapter must only be performed by specially trained repair personnel of the operating company.

Spare parts used must comply with the manufacturer's specified technical requirements.

This is guaranteed if original spare parts are used.

The safe and environmentally friendly disposal of operating materials and replacement parts must be ensured.

The safety instructions in these operating instructions must be observed during maintenance work.

7.1 Care

The care of the product is essentially limited to cleaning all surfaces of the product and – if present – checking the filter inserts.

The warning notices listed in the chapter "Safety notes for maintenance and fault removal" must be observed.

NOTE

The product may not be cleaned with compressed air. This may result in dust and/or dirt particles getting into the ambient air.

Proper care helps to maintain the product in a continuous functional state.

For optimum care and cleaning of the powder-coated surfaces, the following must be observed:

- Thoroughly clean the product monthly or as needed.
- Clean the exterior areas of the product with a suitable industrial vacuum cleaner of dust classification H or with damp soft cloths/industrial cotton wool.
- For stubborn dirt, use commercially available household cleaners. Avoid vigorous rubbing.
- Do not use any abrasive agents that scratch.
- Do not use any acidic or strongly alkaline cleaning agents.
- Do not use organic solvents containing esters, ketones, alcohols, hydrocarbons or similar.

7.2 Maintenance

Regular inspection and servicing have a positive effect on the reliable functioning of the product and should be carried out at least once a year.

Except for the necessary filter replacements, the product operates maintenance-free.

Observe the warning notices for servicing and troubleshooting in the "Safety" chapter.

7.2.1 Special Notes on Laser Welding

NOTE

If the product is used to extract welding fumes from laser welding, more frequent maintenance is required. This applies in particular to regularly checking the dust collection container and emptying it in a timely manner.

Welding fume particles generated by this process may be more reactive and prone to spontaneous combustion. Cleaning and maintenance intervals must be shorter than those for conventional welding processes. Mixing of the dust with particles from other welding or machining processes must be avoided. The level of the dust collection container must be checked regularly and kept as low as possible.

7.2.2 Changing the filter – Safety instructions

The life of the filter inserts depends on the type and amount of deposited particles.

As the dust accumulation in the filter increases, its flow resistance increases and the extraction capacity of the product decreases.

Even with products that may have automatic filter cleaning, adhering deposits can reduce the extraction capacity.

A filter change is required.

⚠ WARNING

Health hazards caused by welding fume particles

Do not inhale welding dust / smoke! Serious injury to the lungs and respiratory tract is possible!

Sweat smoke contains substances that can cause cancer!

Skin contact with welding fume particles can cause skin irritation in sensitive individuals.

To avoid contact with and inhalation of these dust particles, wear disposable overalls, protective goggles, gloves and a suitable Class FFP2 respiratory protection filter mask in accordance with EN 149.

**⚠ WARNING**

Cleaning the filter inserts is not permitted. This inevitably leads to damage to the filter element, meaning the filter ceases to function and hazardous substances enter the air.

During the work described in the following section, pay particular attention to the seal on the main filter. Only an undamaged seal allows the product to achieve a high filter efficiency. Main filters with a damaged seal must therefore be replaced every time.

NOTE

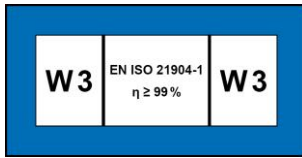

Products with W3 certification according to requirements for W3/IFA certified welding fume separation class. (See "Technical data" chapter)

The W3 approval becomes void if:

- The product is used other than as intended or is subject to constructive modifications.
- Non-original spare parts, in accordance with the spare parts list, are used.

-
- Only original replacement filters, because they guarantee the necessary filter efficiency and are matched to the product and its performance characteristics.
 - Switch the product off using the on/off switch.
 - Secure the product against unintentional switching on. If available, pull out the mains plug or secure the main switch in the 0 position with a padlock.
 - Disconnect the pressure supply, if present, and let the compressed air present in the product flow out via the condensate drain valve.

7.2.3 Changing filters

Perform the filter change as follows:

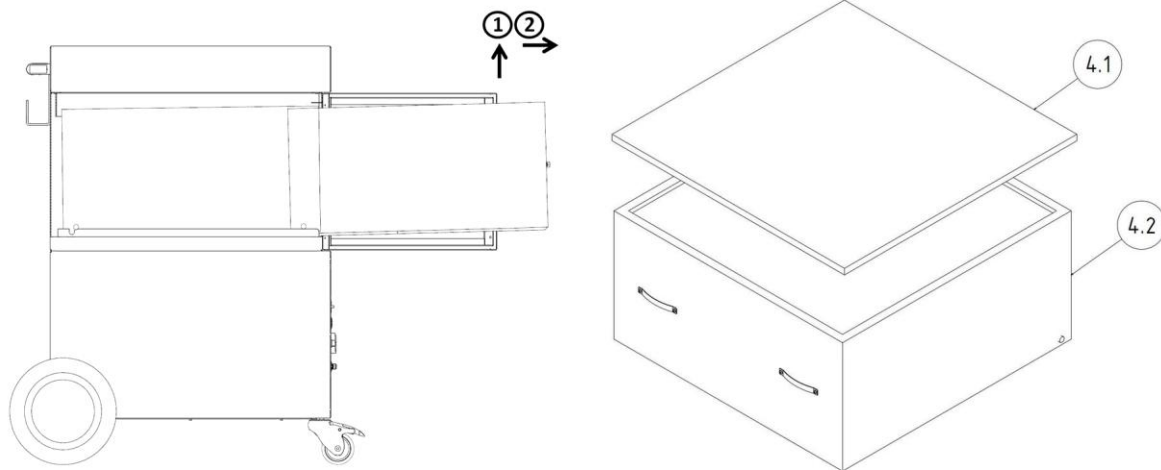

Fig. 7: Changing filters

Changing the pre-filter mat:

1. Carefully remove the pre-filter insert (Pos. 4.1) from the filter section without whirling up dust particles.
2. Remove the clamping bracket that fixes the pre-filter mat.
3. Carefully, without whirling up dust particles, remove the soiled pre-filter mat from the pre-filter insertion frame. Fold the pre-filter mat so that the side covered in dust particles is facing inwards.
4. Put the soiled pre-filter mat into a disposal bag and seal it airtight with a cable tie. Suitable disposal bags are available from the manufacturer.
5. Now, insert a new pre-filter mat into the pre-filter insertion frame and fix it again with the clamping bracket.
6. Reinsert the pre-filter insert into the product.

Changing the main filter:

1. Slightly lift the main filter (Pos. 4.2) at the front using the grip straps in order to separate the seal from the supporting surface. Pull it about two thirds out of the filter housing so that the filter element with the bolt remains on the side guide profiles.
2. At the rear, the main filter slides on side-mounted bolts on guide profiles which causes it to be lifted. This means that the seal is not damaged at the back.

3. Now slide one hand under the side of the filter element and then the other hand. Pull the filter element out of the product using both hands and place it on a work table.
4. Put the soiled filter into a disposal bag and seal it airtight with a cable tie. Suitable disposal bags are available from the manufacturer.
5. Lift the new main filter at the bottom and place it on the guiding profiles of the product with the side bolts. Then, take hold of the front grip straps with one hand and then the other.
6. Lift the filter at the front end and, at the same time, push it backwards into the product until it noticeably engages at the end.
7. Now push the pre-filter insertion frames over the newly inserted main filter.

Please carry out the following steps after changing each filter medium:

1. Close the maintenance door until it noticeably engages.
2. Insert the mains plug into the socket and switch on the product again. The green indicator lamp on the switch indicates fault-free operation.
3. Dispose of used filter elements in accordance with official regulations. Please request the relevant waste codes from the local waste disposal service.
4. Finally, the maintenance area must be cleaned with an industrial vacuum cleaner for dust classification "H".

NOTE

Observe the information printed on the filter element when changing the filter.

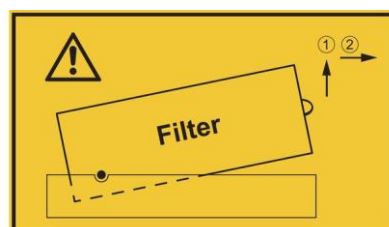



Fig. 8: Information for filter change

7.3 Troubleshooting

Fault	Cause	Note
Not all dust particles are collected	Distance between the extraction hood and the welding position too great	Move the extraction hood closer
	Clean air outlet obstructed	Keep clean air outlet free of obstruction
Signal horn sounds, the green indicator lamp in the switch does not light up	Extraction capacity too low, damper flap in the extraction hood is closed	Fully open the damper flap in the extraction hood
		
Extraction capacity too low/non-existent	Filter inserts saturated	Replace filter inserts
	Phase sequence error/missing phase. The fan is rotating in the wrong direction	Changeover of two phases in the CEE plug by an electrician
Dust particles escape on the clean air side	Filter inserts damaged	Replace filter inserts
Motor protection switch triggers	Motor blocked	Have this checked by a qualified electrician
Product will not start up	No mains voltage	Have this checked by a qualified electrician
	Start/stop sensor (optional fitting) connected, but no current detected Welding process not yet started	Start welding process

Tab. 7: Troubleshooting

7.4 Emergency measures

In case of fire of the product or its detection elements, the following steps should be taken if necessary:

1. Disconnect the product from the mains! If present; pull out mains plug; set main switch to 0-position; disconnect supply fuses.
2. If present, disconnect the compressed air supply.

3. Fight fire with a commercially available dry powder extinguisher.
4. Notify local fire brigade if necessary.

▲ WARNING

Do not open products with maintenance door. Flash flame formation!
In the event of a fire, do not touch the product under any circumstances without proper protective gloves. Risk of burns!

8 Disposal

▲ WARNING

Skin contact with welding fumes, etc. can cause skin irritation in susceptible individuals.

Disassembly work on the product may only be carried out by trained and authorised personnel while complying with the safety rules and the applicable accident prevention regulations.

Serious injury to the lungs and respiratory tract is possible!

In order to avoid contact with and inhalation of dust particles, use protective clothing, gloves and a blower respirator system.

The release of hazardous dust particles must be avoided during dismantling work so that persons in the vicinity are not harmed.

▲ CAUTION

All work on and with the product must comply with the legal obligations for waste avoidance and proper recycling/disposal.

8.1 Plastics

Plastics, if present, must be sorted as far as possible. Plastics must be disposed of in compliance with the legal requirements.

8.2 Metals

Metals, if present, must be separated and disposed of. Disposal must be carried out by an authorised company.

8.3 Filter elements

Filter elements, if present, must be disposed of in compliance with the legal requirements.

9 Annex

9.1 EU Declaration of Conformity

Designation: Welding smoke filter unit
Series: ProfiMaster
Type: 60650, 60650DA (possibly different article numbers for other product variants)
Machine ID: (serial number) see the name plate on the product
This product is developed, designed and manufactured in accordance with EC directives
2006/42/EC – Machinery Directive

The product continues to comply with the provisions of the
2014/30/EU - EMC Directive
2011/65/EU – RoHS Directive

At the sole responsibility of
Company: KEMPER GmbH
Von-Siemens-Str. 20, D-48691 Vreden

The following harmonised standards are used:

EN ISO 12100:2010 Safety of machinery - General principles for design
EN ISO 13857:2019 Safety of machinery - Safety distances
EN ISO 13854:2019 Safety of machinery - Minimum gaps
EN ISO 21904-1:2020 Health and safety in welding and allied processes
EN IEC 61000-6-2:2019 Electromagnetic compatibility (EMC) - Part 6-2: Generic standards - Immunity standard for industrial environments
EN IEC 61000-6-4:2019 Electromagnetic compatibility (EMC) - Part 6-4: Generic standards - Emission standard for industrial environments
EN 60204-1:2018 Safety of machinery - Electrical equipment of machines
EN ISO 13849-1:2023 Safety of machinery - Safety-related parts of control systems

A complete list of standards, directives and specifications applied is available from the manufacturer. The operating manual belonging to the product is available.

Authorised representative:

Kemper GmbH, Von-Siemens-Str. 20, 48691 Vreden, Germany

The aforementioned person is authorised to compile the technical documentation in accordance with Annex VII of Directive 2006/42/EC.

Vreden, 28.05.2026

Place, date

B. KEMPER



CEO

Identification of the signatory

9.2 UKCA Declaration of Conformity

Designation: Welding fume filter unit
Series: ProfiMaster
Type: **60650, 60650DA** (possibly different article numbers for other product variants)
Machine ID: (Serial number) see type plate on product
This product is developed, designed and manufactured in accordance with the UKCA directives
Supply of Machinery (safety) Regulations 2008

The product continues to comply with the provisions of the
Electromagnetic Compatibility Regulations 2016
Electrical Equipment (Safety) Regulations 2016

At the sole responsibility of
Company: **KEMPER GmbH**
Von-Siemens-Str. 20, D-48691 Vreden

The following designated standards and technical specifications have been applied:

BS EN ISO 12100:2010 Safety of machinery - General principles for design
BS EN ISO 13857:2019 Safety of machinery - Safety distances
BS EN ISO 13854:2019 Safety of machinery
BS EN ISO 21904-1:2020 Health and safety in welding and allied processes
BS EN IEC 61000-6-2:2019 Electromagnetic compatibility (EMC) - Part 6-2: Generic standards - Immunity standard for industrial environments
BS EN IEC 61000-6-4:2019 Electromagnetic compatibility (EMC) - Part 6-4: Generic standards - Emission standard for industrial environments
BS EN 60204-1:2018 Safety of machinery - Electrical equipment of machines
BS EN ISO 13849-1:2023 Safety of machinery - Safety-related parts of control systems
BS EN IEC 63000:2018 Technical documentation for the assessment of electrical and electronic products with respect to the restriction of hazardous substances

A complete list of standards, directives and specifications applied is available from the manufacturer. The operating manual belonging to the product is available.
Additional information:

UK Authorised Representative:
United Kingdom KEMPER (U.K.) Ltd.
Venture Court, 2 Debdale Road, Wellingborough, Northamptonshire NN8 5AA
The above-mentioned person is authorized to compile the technical documentation in Schedule 2 of the Supply of Machinery (Safety) Regulations 2008.

Vreden, 28.05.2026
Place, date

B. Kemper

CEO
Identification of the signatory

9.3 Technical data

Designation	Type	
Filters	60650	60650DA
Filter stages	2	
Filter method	Disposable filter	
Cleaning method	--	
Filter surface m ² [ft ²]	17 [183]	
Number of filter elements	1	
Total filter surface m ² [ft ²]	17 [183]	
Type of filter	Filter cassette	
Filter material	Non-woven fibre	
Filter efficiency ≥ %	99.5	
Welding fumes class	W3	-
IFA test standard	DIN EN ISO 21904-1+2	-
Filter class/dust classification	E12	
Basic data		
Maximum fan capacity m ³ /h [CFM]	2200 [1295]	
Extraction capacity m ³ /h [CFM]	1100 [647]	2 x 700 [2 x 412]
Vacuum Pa [inch WC]	2250 [9]	2400 [10]
Minimum extraction capacity (triggering threshold for volume flow monitoring) m ³ /h [CFM]	700 [412]	
Motor power kW [hp]	1.1 [1.48]	
Power supply/rated current/protection type/ISO class	See name plate	
Permissible ambient temperature (operation) °C [°F]	+5 to +40 [+41 to +104]	
Duty cycle %	100	
Noise level dB(A)	72	
Compressed air supply bar [PSI]	--	
Compressed air consumption NI/min [CFM]	--	
Compressed air class		

Dimensions of the basic product W x H x D	See Dimensions sheet
Basic product weight kg [lbs]	109 [241]
Additional information	
Fan type	Radial fan

Table 8: Technical data

9.4 Dimensions sheet

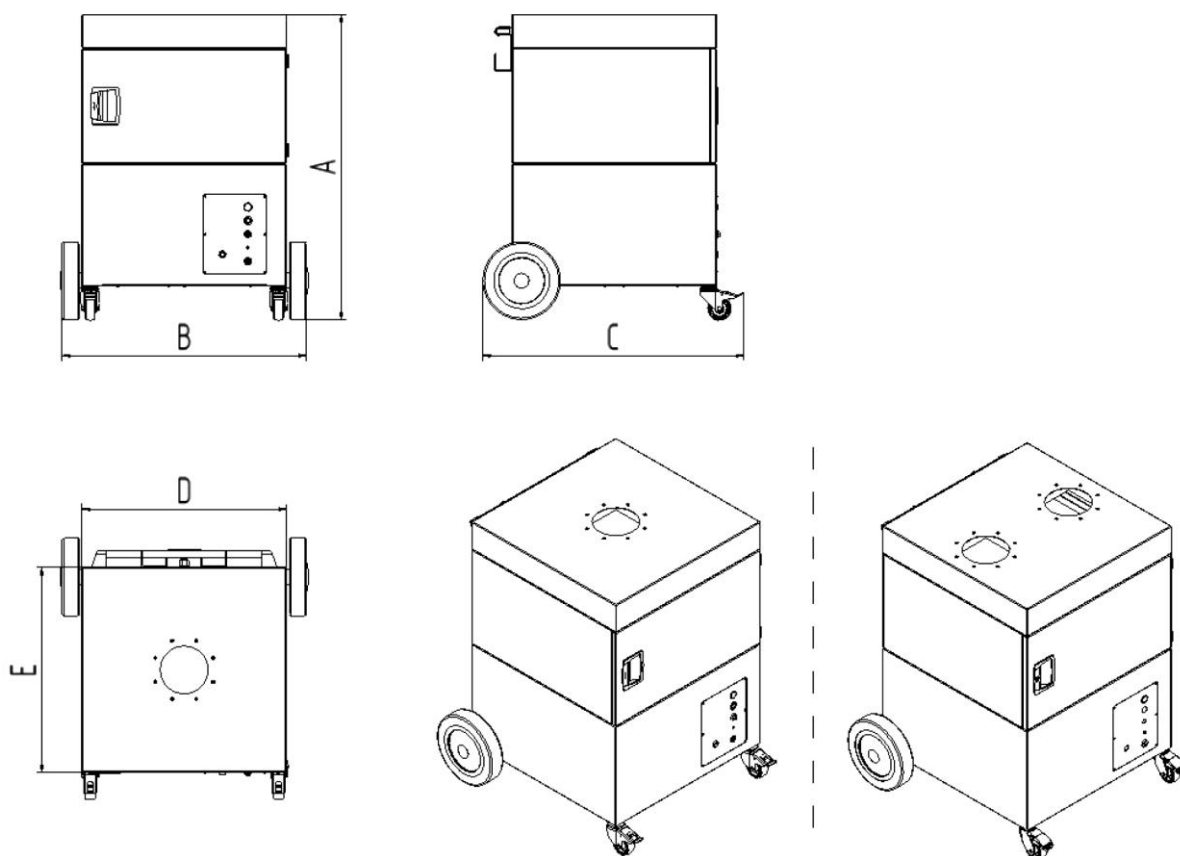

Fig. 9: Dimensions sheet 60650 + 60650DA

Symbol	Dimensions mm [in]	Symbol	Dimensions mm [in]
A	997 [39.3]	D	655 [25.8]
B	793 [31.2]	E	655 [25.8]
C	836 [32.9]		

Tab. 9: Dimensions table 60650 + 60650DA

9.5 Spare parts

Consec. No.	Description	Part no.
1	Pre-filter mat (pack of 10)	1090033
2	Main filter	1090457
3	Waste disposal bags for filters (pack of 10)	1190746
4	Wheel set	6430007

Table 10: Spare parts

9.6 Accessories

Consec. No.	Description	Part no.
1	Exhaust air connection NW 200 mm for outgoing air hose	1350260
2	Automatic start/stop	94102781

Table 11: Accessories

Deutschland (HQ)**KEMPER GmbH**

Von-Siemens-Str. 20
D-48691 Vreden
Tel. +49 2564 68-0
Fax +49 2564 68-120
mail@kemper.eu
www.kemper.eu

United Kingdom**KEMPER (U.K.) Ltd.**

Venture Court
2 Debdale Road
Wellingborough
Northamptonshire NN8 5AA
Tel. +44 1327 872 909
Fax +44 1327 872 181
mail@kemper.co.uk
www.kemper.co.uk

France**KEMPER sàrl**

7 Avenue de l'Europe
F-67300 Schiltigheim
Si vous appelez de France
Tél. +33 800 91 18 32
Fax +33 800 91 90 89
De Belgique ou de l'étranger
Tél. +492564 68-135
Fax +492564 68-40135
mail@kemper.fr
www.kemper.fr

China**KEMPER China**

Floor 2, Building 6
No. 500 Huapu Road
Shanghai 201799
P.R. of China
Tel. +86 (21) 5924-0978
Fax +86 1852-1069-401
info@kemper-china.com.cn
www.kemper.cn.com

Ceská Republika**KEMPER spol. s r.o.**

Pyšelská 393
CZ-257 21 Porčí nad Sázavou
Tel. +420 317 798-000
Fax +420 317 798-888
mail@kemper.cz
www.kemper.cz

United States**KEMPER Fume****Extraction Systems LLC**

31465 Stephenson Hwy
Madison Heights
MI, 48071 USA
ph+1 (312) 815 5656
info@kemper-na.com
kemper-na.com

Canada**KEMPER Fume****Extraction Systems**

1-2, 1249 Seagrave Road
Woodstock, ON, N4T 0A8,
Canada
ph+1 (312) 815 5656
info@kemper-na.com
kemper-na.com

Nederland**KEMPER B.V.**

Demmersweg 92
Begane grond
7556 BN Hengelo
Tel. +492564 68-137
Fax +492564 68-120
mail@kemper.eu
www.kemper.eu

España**KEMPER IBÉRICA, S.L.**

Avda Diagonal, 421 3º
E-08008 Barcelona
Tel. +34 902 109-454
Fax +34 902 109-456
mail@kemper.es
www.kemper.es

India**KEMPER India**

55, Ground Floor, MP Mall
MP Block, Pitam Pura
New Delhi -110034
Tel. +91.11.42651472
mail@kemper-india.com
www.kemper-india.com

Polska**Kemper Sp. z o.o.**

ul. Grzybowska 87
00-844 Warszawa
Tel. +48 22 5310 681
Faks +48 22 5310 682
info@kemper.pl
www.kemper.pl

